

- 1 Base Station
- 2 Sensor Case with PCB and Battery

## WIRELESS PROCESS MONITORING AND CONTROL

### Fraunhofer Institute for Microelectronic Circuits and Systems IMS

Finkenstr. 61  
D - 47057 Duisburg  
Phone +49 203 37 83-0  
Fax +49 203 37 83-266  
[www.ims.fraunhofer.de](http://www.ims.fraunhofer.de)

#### Contact

Michael Bollerott  
Phone +49 203 37 83-227  
[vertrieb@ims.fraunhofer.de](mailto:vertrieb@ims.fraunhofer.de)

### Wireless Temperature Measurement

Numerous manufacturing processes require strict compliance with a dedicated temperature profile in order to achieve the target quality of a product, for example a baking process in the food industry, drying and hardening processes for adhesive bonds or soldering processes for the manufacturing of electronic assembly groups.

In many cases it is no problem to attach sensors to the points of interest and connect them using cables for power-supply and readout.

But there are also applications in which wiring of standard sensors is impossible for various reasons, for example if sealed chambers don't allow cable penetration, if the point of interest is moving or rotating, or if the environment is not suitable for a secure laying of cables.

In these applications the use of wireless sensors is an appropriate means.

### Soldering Process Monitoring

For the monitoring and control of a reflow soldering process Fraunhofer IMS has developed a prototypic system based on battery-powered wireless temperature sensors.

These sensors are driven through the soldering furnace very close to the assembly group to be soldered and determine the temperature profile at the soldering location with high accuracy and high temporal resolution. Measurement data is wirelessly sent to a dedicated base station using a proprietary real-time TDMA communication protocol in the UHF ISM frequency band at 868 MHz.

In addition to the measurement accuracy, which is important for the soldering quality, there are further requirements for the sensors and the whole system that had to be met.



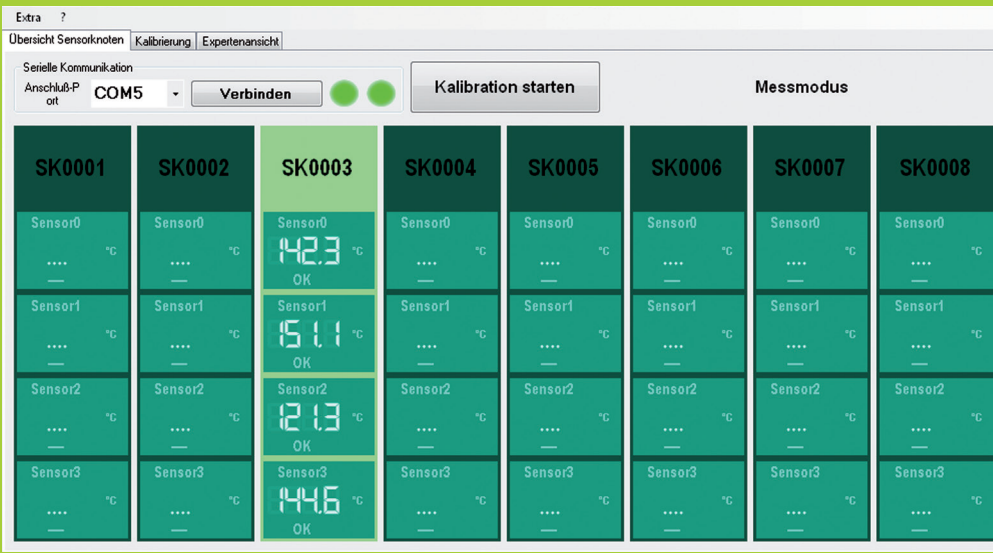

An important issue for the soldering process monitoring application is the encapsulation of the sensor. It is essential for the mechanical stability of the sensor and for its protection against aggressive media. It has to withstand the high temperature during the soldering process and it must not outgas any substances that are critical for the soldering quality. Any contamination of the soldering atmosphere has to be avoided. This requirement could be met by the sensor.

The system offers the advantage that in case of a malfunction of a sensor element only the related sensor has to be replaced, because the sensor is not mounted at a fixed position within the furnace, but goes through the process together with the assembly group to be soldered. Therefore in opposition to conventional sensor solutions there is no standstill of the facility during maintenance or replacement of sensors.

### System Architecture

The overall system consists of the following components:

- a base station with UHF wireless frontend and USB interface (optional: LAN interface)
- up to 28 wireless sensors with up to 4 temperature sensor elements each (either platinum based RTDs or thermocouples type K)
- PC software for visualization of measurement values.

In order to minimize the energy consumption of the sensor a wake-up interface has been implemented that works with an LF signal at 133 kHz frequency.

Directly before entering the soldering furnace the sensor will be woken up from sleep-mode. The sensor performs a self-test and starts temperature measurement. After leaving the furnace the sensor enters sleep-mode again.

The sensors transmit their measurement values to the base station using a real-time TDMA communication protocol, similar to that used in a cellular based mobile phone system like GSM. In this system up to 28 sensors can communicate with one base station without data packet collision.

### Special System Properties

- real-time wireless communication from out of the soldering furnace using UHF ISM band at 868 MHz
- collision-free wireless transmission with up to 28 sensors
- minimal energy consumption by sleep-mode and LF wake-up mechanism (133 kHz)
- high temperature stability of the sensors up to 125 °C
- high measurement rate (3 Hz)
- Chemical resistance against aggressive media
- no impact on the soldering atmosphere by outgassing
- suitable for operation in vacuum

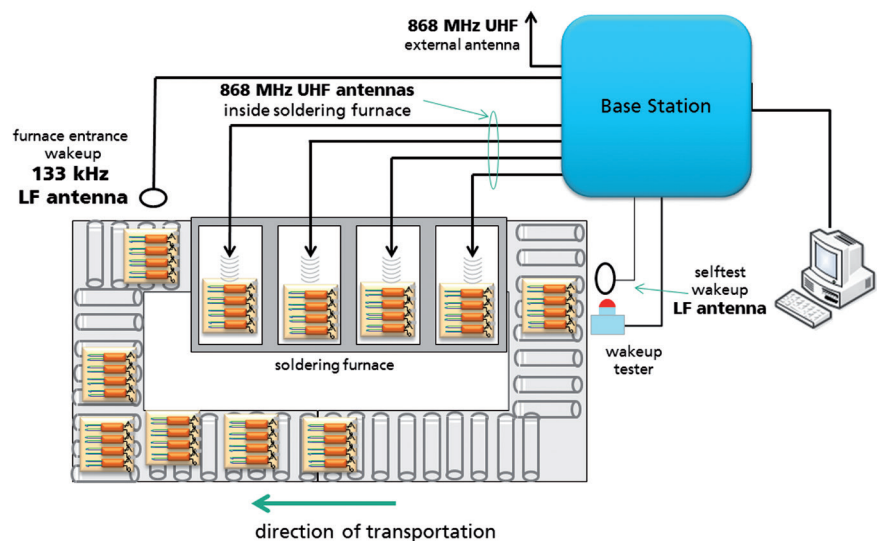

3 Data Visualization

4 Soldering Monitoring Application